

Design and Simulation of an Intelligent Laser Tracking System

T. A. Khaled, M. M. Elkhatib, and A. F. El-Sherif

Military Technical College, Cairo, Egypt

Email: Tarekfathy81@yahoo.com, elkhatib.m@googlemail.com, Ashraf.AISharif@staff.aast.edu

Abstract—In a Laser Tracking System (LTS) the control objective is for a laser beam to track targets. This is done based on the returning laser beam, as measured by a four-quadrant photodetector is required to be centered in the surface of Quad Detector (QD). This brief shows that Fuzzy logic controllers (FLC) can outperform classic controllers in such applications. The advantages of utilizing a Proportional–Integral–Derivative (PID) like fuzzy controllers to improve the control performance for a system with noise and a relatively long time delays is confirmed by simulation results. To have a complete designation and tracking system, an experimental characterization is presented including current verses voltage curves, output optical power verses drive current curves, temperature dependence of wavelength is illustrated and a laser modulation with a specific PRF code was developed.

Index Terms—fuzzy control, laser measurement applications, target tracking

I. INTRODUCTION

An accurate Guidance of Air to ground missiles and bombs is needed to hit the right targets so it's important to solve the tracking problems. It requires a high performance control algorithm to guide them to the intended targets. For those munitions using a laser seeker, an intelligent control system is needed to quickly guide the seeker with incoming laser reflected from targets to be tracked.

Fuzzy logic is a branch of artificial intelligence that deals with approximate reasoning algorithms used to emulate human thinking and decision making in machines. These algorithms are used in applications where process data cannot be represented in binary form. So it's a way of mathematically analyzing the uncertainty of information; it's a way of dealing with information that is "gray" in nature [1].

Fuzzy logic provides a practical, inexpensive solution for controlling complex or ill-defined systems. Despite its contradictory-sounding name, fuzzy logic offers a rigorous framework for solving many types of control problems. Rule-based fuzzy controllers require less code and memory and don't need heavy number-crunching or complex mathematical models to operate. All that is needed is a practical understanding of the overall system behavior improvement in reducing noise effects on the

tracking error when used in Laser tracking systems [1], [2].

The experimental results of [3] showed that the position accuracy of the crane was greatly improved by using that fuzzy control strategy. In addition, the of a fuzzy PID controller for a mechanical manipulator, both dynamic transient and steady-state performances of the manipulator could be significantly improved despite notable uncertainties of the system [4].

Also, the use of a microprocessor-based fuzzy logic tracking controller for motion controls and drives, indicates an excellent tracking performance for both speed and position trajectories [5].

In this work, Laser Tracking Systems (LTS) are designed to detect and track the targets by getting the position information of these targets. The system consists of an optical system to collimate the reflected beam from the targets, the Position Sensitive Detector (PSD) which convert the incident laser spot to its corresponding photocurrent, and the readout circuits that convert the photocurrent to its corresponding voltage.

One of the main component of the laser tracking system is the Quad Detector (QD) which is simply consists of four photodiodes capable of detecting light spot projected on its surfaces and determine the deviation position of the laser spot from its center.

Laser spot QD readout circuit consists of a preamplifier stage, a post amplifier, a reciprocal amplifier, and an analog to digital converter.

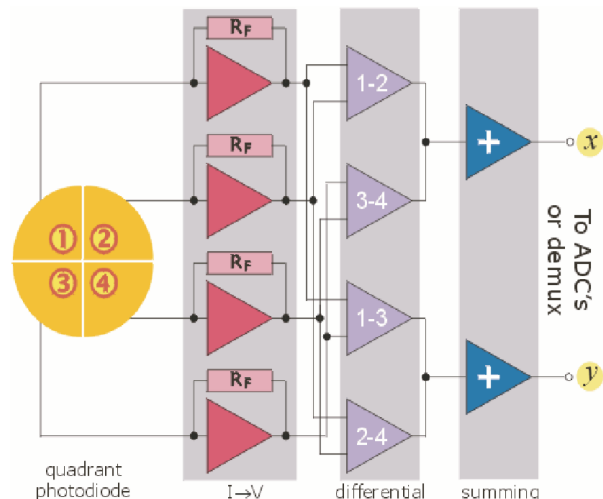

Figure 1. The general block diagram of the four quadrant detector with processing circuit for laser position determination.

Starting from the output of the quadrant photodiode detector, the output current of the photodiode is a small value in the range of μA , so that a trans-resistance amplifier is used to get output voltage to be used as shown in Fig. 1.

This paper focus on designing an intelligent algorithm to enhance Laser Detection System (LDS) by using a microcontroller to implement the function of the 2nd and 3rd stage of the block diagram shown in Fig. 1. The algorithm uses fuzzy logic to control of a servo motor which improve the tracking performance by moving the QD with the laser beam reflected from the target and make the laser spot incident on its surface always in its centroid position.

II. OPERATING PRINCIPLES OF THE LTS

A. Laser Tracking Principles

The light amplification by stimulated emission of radiation (laser) is the enabling technology of more precise weapons. Laser systems enable joint forces to engage a wider range of targets with more accuracy and fewer munitions than previously possible [6].

Laser designators emit a narrow beam of laser pulses which is susceptible to degradation from atmospheric scatter and a variety of target reflections [6].

Laser designators and seekers use a pulse coding system to ensure that a specific seeker and designator combination work in harmony. By setting the same code in both the designator and the seeker, the seeker will track only the energy with the correct coding. The pulse coding is based on Pulse Repetition Frequency (PRF) [6].

Illustrates IR and laser equipment compatibility is shown in Fig. 2. As depicted, compatibility exists only between Laser Target Detection systems (LTDs) and Laser Spot Tracking systems (LSTs). In other words, all coded laser target designators can work with all coded laser acquisition and/or spot trackers and all coded laser-guided weapons. IR pointers and night vision goggles (NVGs) are only compatible with each other. IR pointers cannot designate for LSTs, and NVGs cannot see the LTD mark. Forward-Looking Infrared (FLIR) systems are not compatible with LTDs, LSTs, and/or IR pointers [6].

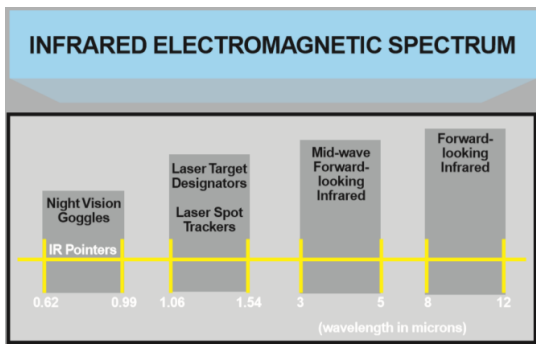

Figure 2. Infrared electromagnetic spectrum.

B. Quad Detector Structure

The invention is generally directed to a Laser Spot Tracking System (LSTS) to simultaneously process

multiple targets with position and code data. Laser spot trackers have been used for many years to steer a weapon system onto target. Typically a pulsed narrow beam laser illuminates the target then the laser light is scattered from the target. The tracker or seeker lens collects the some of the scattered light and condenses it into a spot. The tracker is steered until the spot is divided equally into four equal signals normally using a quad detector shown in Fig. 3a and Fig. 3b the null position. In this position the tracking head bore sight is pointed at the target [7].

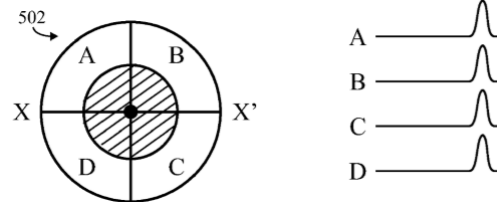

Figure 3a. Light spot incident on the center of the quad detector.

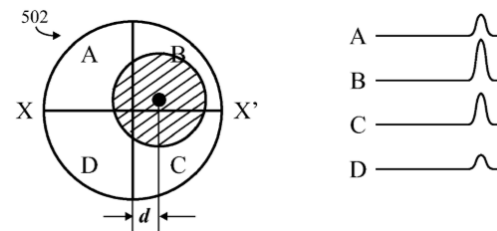

Figure 3b. Light spot incident with a shift of distance d from the center of the quad detector.

A P-Type Quad Silicon Detector (product data sheet for Model SD 551-23-41-221) as shown in Fig. 4 is used experimentally in this project. The detector is a (Near Infrared) NIR enhanced silicon P-type detector used for application requiring fast response with low capacitance and high responsivity packaged in a hermetic TO-8 metal package. [8]

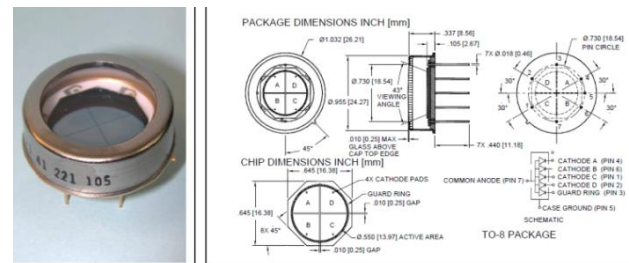

Figure 4. A P-type quad silicon detector.

There are two ways used to process the signals. The “bang-bang” method compares opposite quadrants or directions and the spot is dithered around the null position as the comparators make a series of corrections. A typical “bang-bang” system is described in [9].

A second more complex method, which is used in this paper, measures the peak amplitudes of the signal in each of the four channels. If the four quadrants are A, B, C and D, then one axis is (A+B)-(C+D) and the other axis is (A+D)-(B+C). Dividing by the sum channel, (A+B+C+D), may normalize these signals. This approach may give a proportional area to optimize the response of the tracking elevation and azimuth servos [10].

The center on a quadrant photodiode is found by:

$$X = \frac{(A + D) - (B + C)}{A + B + C + D}$$

$$Y = \frac{(A + B) - (C + D)}{A + B + C + D}$$

This method has been implemented and simulated as shown in Fig. 5. The output of the read out circuit that convert the photocurrent to its corresponding voltage which then connected to a microcontroller to do the deferential and summation part.

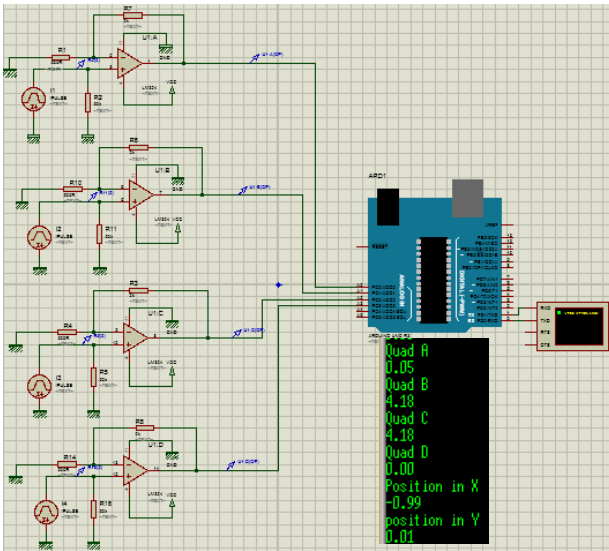

Figure 5. The simulation of the quad detector signal processing.

The output of the microcontroller has been processed by the proposed fuzzy system to control servo motors to center the spot position on the quad detector.

III. DESIGN OF FUZZY LASER TRACKING CONTROLLER

Fuzzy logic has rapidly become one of the most successful of today's technologies for developing sophisticated control systems. The fuzzy controller has four main components [11]:

- 1) The Rule-Base holds the knowledge, in the form of a set of rules.
- 2) The Inference Mechanism evaluates which control rules are relevant at the current time and then decides what the input to the plant should be.
- 3) The Fuzzification Interface simply modifies the inputs so that they can be interpreted and compared to the rules in the rule-base.
- 4) The Defuzzification Interface converts the conclusions reached by the inference mechanism into the inputs to the plant.

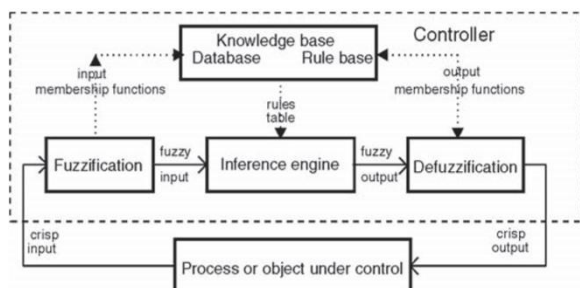

Figure 6. The basic structure of the fuzzy logic controller.

The design of the FLC followed the standard steps of defining input and output Membership Functions (MFs), constructing a number of control rules, and mapping these rules to a lookup table that produced final defuzzification output values. [12] The following Fig. 6 shows the fuzzy logic controller basic structure

The proposed system has two inputs, the detector deviation signal and the rate of the error signal, and one output signal to control the motors. It uses Mamdani fuzzy system with five membership function (five-label) fuzzy sets for the two inputs (Rate & Deviation) and seven membership function fuzzy sets for the output (Movement) as shown in Fig. 7.

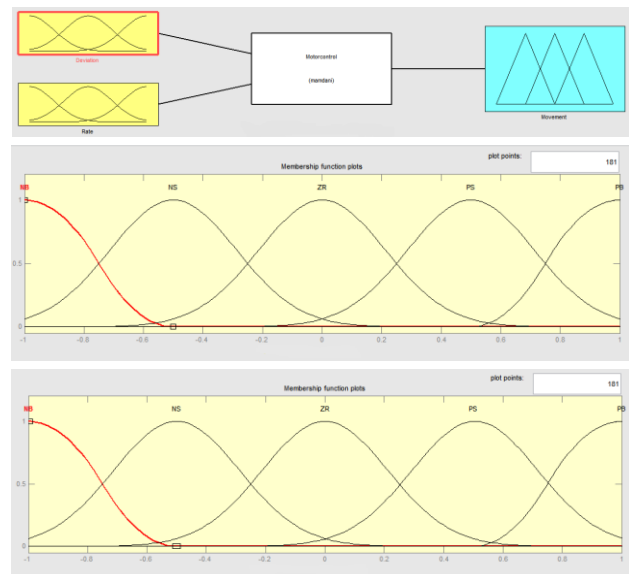

Figure 7. The proposed fuzzy system.

It was found that using the Z function, the S function at the ends of membership functions (MFs) and Gaussian shaped membership functions at the rest of MFs yielded smoother tracking performance and faster time responses than FLCs that used either triangular or trapezoidal membership functions.

The proposed system has a set of linguistic variables to represent the output control signal, five Gaussian MFs, one S-shape MF and one Z-shape MF as shown in Fig. 8. These MFs were defined as: negative big (NB), negative medium (NM), negative small (NS), zero (ZR), and positive small (PS), positive medium (PM) and positive big (PB).

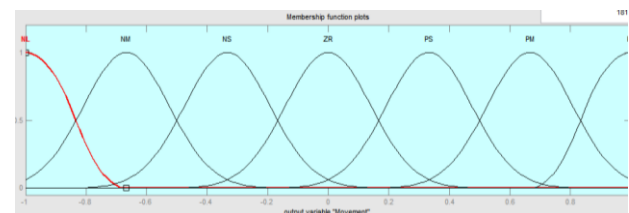

Figure 8. The output membership functions.

A total of 25 rules were constructed for the vertical tracking axis control shown in Table I.

The control surface of the proposed system shown in Fig. 9.

TABLE I. THE PROPOSED SYSTEM RULE BASE

Rate Error	PB	PS	ZR	NS	NB
PB	PM	PM	PM	PB	PB
PS	PS	PS	PS	PM	PM
ZR	NS	NS	ZR	PS	PS
NS	NB	NM	NS	NS	NS
NB	NB	NB	NM	NM	NB

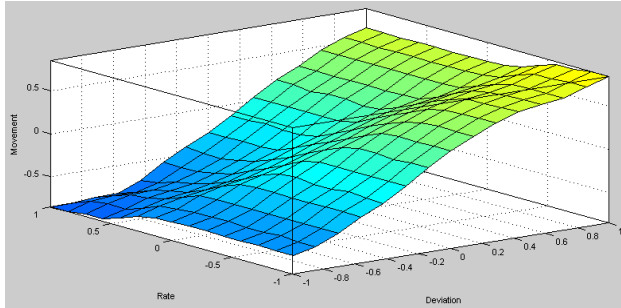

Figure 9. The proposed system control surface.

The rules were formulated one by one, and then the whole rules set were analyzed to make it:

- Complete: if any combination of the inputs fired at least one rule.
- Consistent: if it does not contain any contradictions.
- Continuous: if it does not have neighboring rules with output fuzzy sets that have an empty intersection.

Once the lookup table was constructed, no further modification of its structure or entries was ever attempted. The model of the motor and its drive system was actually identified by using MATLAB Identification Toolbox.

Although much of the opposition to fuzzy logic is based on misconceptions, fuzzy control is not a cure-all. Fuzzy control should not be employed if the system to be controlled is linear, regardless of the availability of its model. PID control and various other types of linear controllers can effectively solve the control problem with significantly less effort, time, and cost. PID control should be tried first whenever possible [1]. The benefits of fuzzy controllers can be summarized as follows:

- 1) Fuzzy controllers are more robust than PID controllers because they can cover a much wider range of operating conditions than PID, and can operate with noise and disturbances of a different nature.
- 2) Developing a fuzzy controller is cheaper than developing a model-based or other controller to do the same thing.
- 3) Fuzzy controllers are customizable, and it is easier to understand and modify their rule, which not only uses a human operator's strategy, but is also expressed in natural linguistic terms.
- 4) It is easy to learn how fuzzy controllers operate and how to design and apply them to a concrete application it is also worth noting that fuzzy logic can be blended with conventional control techniques. This means that fuzzy systems do not necessarily replace conventional control methods. In many cases fuzzy systems augment them and simplify their implementation [12].

The proposed system is modeled and simulated based on PID like fuzzy logic controller as shown in the block diagram Fig. 10.

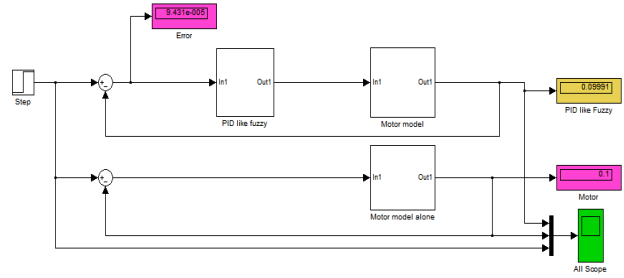

Figure 10. The proposed system block diagram.

The simulation results, as shown in Fig. 10 is a comparison between the output of a servo motor without and with using PID like fuzzy control technique shown in Fig. 11.

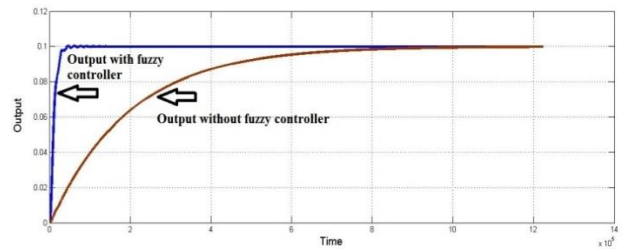

Figure 11. The simulation results.

In order to have a complete system an experimental results for producing a high power laser has been carried out. The produced laser used to designate the targets so that the reflected and scattered laser can be detected using the quad detector.

IV. EXPERIMENTAL RESULTS OF CHARACTERIZATION AND MODULATION OF HIGH POWER SOLID STATE LASER

The operation of high power laser diode and the wavelength stabilization is described. Experimental characterization is presented including current verses voltage curves, output optical power verses drive current curves, temperature dependence of wavelength is illustrated and a laser modulation with a specific PRF code was developed.

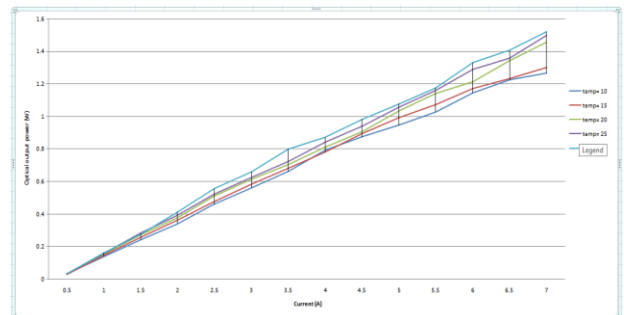

Figure 12. The optical characteristics (L-I) curve of the high power diode module.

Firstly, the Optical characteristics (L-I) curve of the high power diode module at operating temperature of

different values was investigated to determine the highest power can be achieved which is 1.88 Watt at temperature 30 °C as shown in Fig. 12.

Secondly, the wavelength stability was investigated to achieve the most stable wavelength at a certain temperature which is 20 °C, the moderate wavelength stability is at temperature 25 °C and the wariest wavelength stability is at temperature 30 °C & 35 °C is shown in Fig. 13.

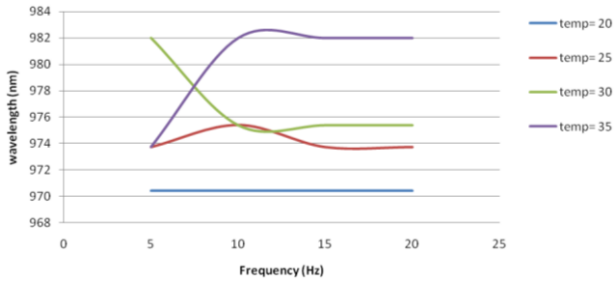

Figure 13. The wavelength versus frequency.

Finally, the responsivity of the output diode laser versus different frequencies was investigated after modulation of the laser output with different frequencies 5, 10, 20, 25Hz.

It was found that it has high pulse to pulse stability at all frequencies as shown in Fig. 14A, Fig. 14B, Fig. 14C, and Fig. 14D.

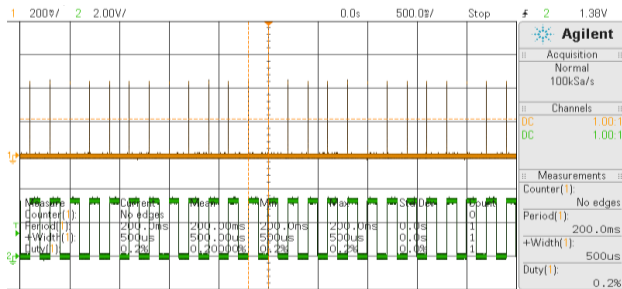

Figure 14A. The pulse to pulse stability at 5Hz.

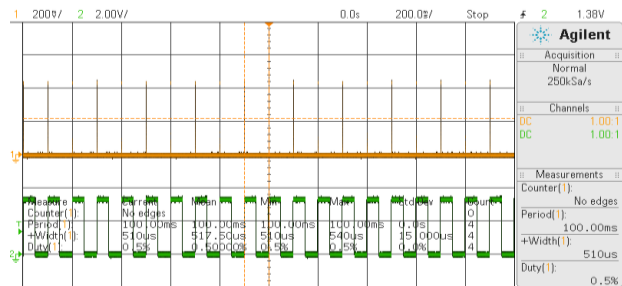

Figure 14B. The pulse to pulse stability at 10Hz.

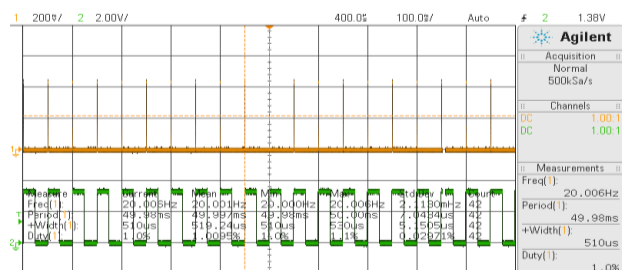

Figure 14C. The pulse to pulse stability at 15Hz.

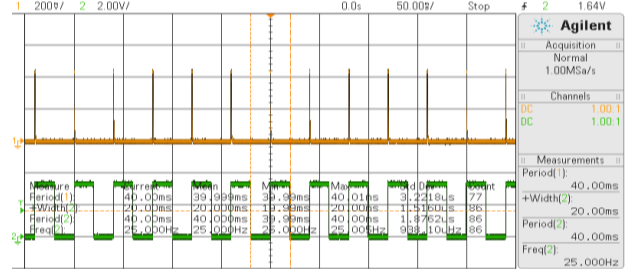

Figure 14D. The pulse to pulse stability at 15Hz.

And the diode wavelength was measured at different operating temperatures controlled by the laser diode driver and temperature controller (within the diode operating temperature acceptance 0:60 °C) with different driving currents as shown in Fig. 15A, Fig. 15B, Fig. 15C, and Fig. 15D.

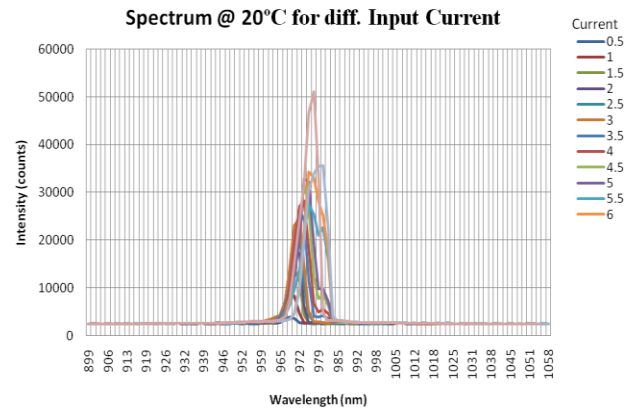

Figure 15A. The measured wavelength at 20 °C.

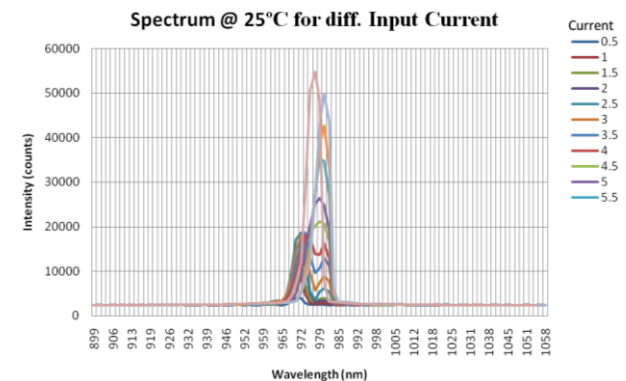

Figure 15B. The measured wavelength at 25 °C.

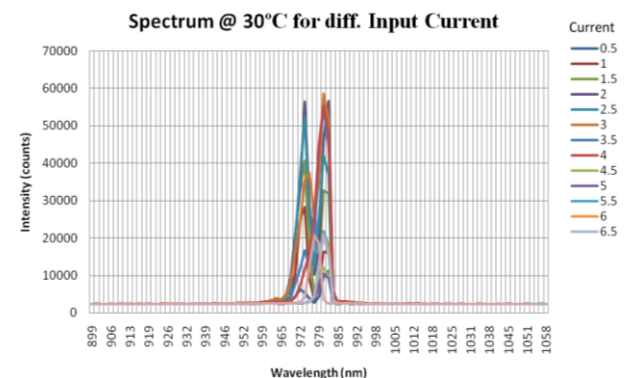

Figure 15C. The measured wavelength at 30 °C.

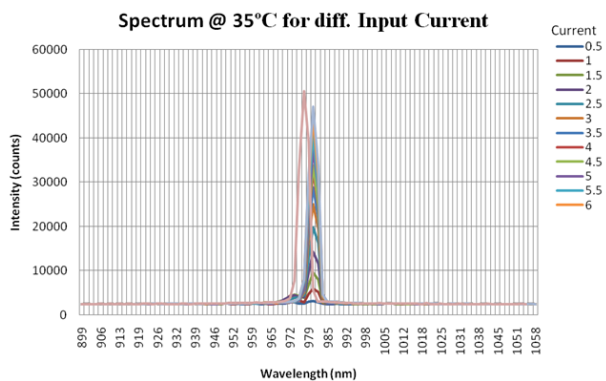

Figure 15D. The measured wavelength at 35 °C.

V. CONCLUSION

The goal of this study is to develop control strategies for LTS that exhibit high-precision tracking and measurement performances. The control objective is to minimize the target tracking error during the tracking measurement process with high speed response action.

This paper presents an analysis and performance evaluation of PID-like fuzzy logic controller designed and modeled using Matlab/Simulink software. The simulation results show that the PID like fuzzy logic controller improves the tracking performance of the servo motor.

Due to the fast and precious issue of laser tracking problem, it is suitable to use Fuzzy controllers which are more robust and can cover a much wider range of operating conditions. In addition, it can deal better with noise and disturbances of a different nature.

Finally, to have a complete designation and tracking system, the operation of high power laser diode and the wavelength stabilization is described. Experimental characterization is presented including current verses voltage curves, output optical power verses drive current curves, temperature dependence of wavelength is illustrated and a laser modulation with a specific PRF code was developed.

REFERENCES

- [1] Y. Bai, H. Zhuang, and Z. S. Roth, "Fuzzy logic control to suppress noises and coupling effects in a laser tracking system," *IEEE Transactions on Control Systems Technology*, vol. 13, no. 1, pp. 113-121, 2005.
- [2] M. Y. Shieh and T. S. Li, "Implementation of integrated fuzzy logic controller for servomotor system," in *Proc. International Joint Conference of the Fourth IEEE International Conference on Fuzzy Systems and The Second International Fuzzy Engineering Symposium on Fuzzy Systems*, 1995.
- [3] C. S. Li and C. Y. Lee, "Fuzzy motion control of an auto-warehousing crane system," *IEEE Transactions on Industrial Electronics*, vol. 48, no. 5, pp. 983-994, 2001.
- [4] W. Li, *et al.*, "Design of an enhanced hybrid fuzzy P+ID controller for a mechanical manipulator," *IEEE Transactions on Systems, Man, and Cybernetics, Part B: Cybernetics*, vol. 31, no. 6, pp. 938-945, 2001.
- [5] A. Rubaai, D. Ricketts, and M. D. Kankam, "Laboratory implementation of a microprocessor-based fuzzy logic tracking controller for motion controls and drives," *IEEE Transactions on Industry Applications*, vol. 38, no. 2, pp. 448-456, 2002.

- [6] V. E. Clark, *Joint Tactics, Techniques, and Procedures for Laser Designation Operations*, United States Joint Chiefs of Staff, May 1999, pp. 149.
- [7] I. D. Crawford, *et al.*, "Laser spot tracker and target identifier," Google Patents, 2010.
- [8] Advanced Photonix. High voltage P-type quad silicon detector. SD 551-23-41-221. [Online]. Available: www.advancedphotonix.com
- [9] D. W. Coffey and M. G. Woolfson, "Bang-Bang laser spot tracker," United States Patent 6097481, Aug. 1, 2000.
- [10] I. D. Crawford, *et al.*, "Laser spot tracking with off-axis angle detection," Google Patents, 2013.
- [11] J. K. Huang, "Hybrid fuzzy PID controller with adaptive genetic algorithms for the position control and improvement of magnetic suspension system," Master thesis, National Sun Yat-Sen University, 2004.
- [12] L. Reznik, *Fuzzy Controllers*, Newnes, 1997.



Tarek Ahmed Khaled was born in Al Ismailia, Egypt in 1981. He received the B.Sc. degree from Electronics Engineering Department, Military technical Collage, Cairo, Egypt in 2003. He is currently doing his M.Sc. degree in a design of high power laser tracking system with the cooperation of Engineering Physics Department and Electronics Engineering Department.



Mohamed Misbah Elkhatib received the B.Sc. and M.Sc. degrees from Military Technical College, Cairo, Egypt in 1994 and 1999 respectively. He received the PhD from University of Strathclyde, Glasgow, United Kingdom in Dec. 2007. He worked as Consultant and Analog Circuit Designer, for many companies in UK and Egypt. He joined the Electronics Engineering Department, Military Technical College as assistant professor since 2008 and till now. He also a Visiting Lecturer to many Egyptian Universities. He served as Technical reporter (organization Board) of the 6th International Scientific Conference of the Military Technical College, ISC-MTC-6, 2012. And Conference Rapporteur Assistant of the 9th International Conference on Electrical Engineering (ICEENG-9). He is also one of the technical panels of "IEEE European DSP Education & Research Conference". His research interests include modeling and characterization of MOS devices, Sensors read out circuits, mixed-mode VLSI design, Low power circuit design, ASICs for control applications, Intelligent control systems, Fuzzy systems, Mechatronics control systems design and wireless sensor nodes.



Ashraf Fathy El-Sherif achieved a Professor Doctor January 2015, and he is a lecturer and faculty member within Engineering Physics Department, MTC, Cairo, Egypt. Also, he is the Head of the Laser Technology Center; the Chairman of Engineering Physics Department Scientific Board. He has over 8 years' experience in diode-pumped solid-state and fiber laser research and development. He served as a post-doctoral research at CREOL, College of Optics & Photonics, University of Central Florida, Orlando, USA in 2012-2013, and as a research scientist at LPL, Laser Townes Institute, CREOL, USA. He achieved an Associate Professor title in October 2009. He got his PhD in laser photonics and modern optics, from Laser Photonics Research Group, University of Manchester, UK, in 2003, Field of research interests are the design of new types of laser sources operating at NIR and MIR bands like diode pumped high power solid state laser (DPSS), and diode pumped high power fiber lasers and their remote sensing, spectroscopy and military applications as well as laser in medicine, like OCT, optical imaging, laser induced photoemission, photothermal and photoacoustic for diagnosis of human diseases.